

## HA10VSO/52 系列变量柱塞泵 Variable displacement Pump HA10VSO/52

规格 size 10

52 系列 series

额定压力可达 25MPa Nominal pressure 25MPa

峰值压力可达 31.5MPa Peak pressure 31.5MPa



### 目录 Ordering Code

一、型号说明 Ordering Code.....	74
二、油液 Hydraulic Fluid .....	75
三、技术参数 Technical data.....	75
四、安装注意事项 Installation Notes.....	75
五、安装连接尺寸 Mounting Dimension.....	76-79
六、控制方式 Controller.....	80-81

### 特点 Features

1、用于开式回路的斜盘式轴向柱塞泵。

Swash plate design axial variable piston pump used in open circuit.

2、连续工作压力可达 250bar, 瞬时最高工作压力可达 315bar。

Continuous working pressure can reach 250bar, the highest instantaneous working pressure can reach 315bar.

3、流量正比于驱动转速和排量, 并可通过调节斜盘倾角实现无级变量。

The flow is directly proportional to the drive rotate speed and the displacement, and can make stepless variable come true by adjusting the obliquity of the swash plate.

4、有恒压、恒流量等多种控制方式, 且控制响应速度快。

Wide range of controls such as DR ,DRG ,DFR1 etc. Short response times.

5、低噪音、高效率、高可靠性、长寿命。

Low noise level, high efficiency, high reliability and long service life.

6、体积小、功率密度高。

Small volume, High power density.

7、优良的吸油性能。

Excellent oil absorbency

8、驱动轴能承受轴向和径向负载。

Axial and radial loading of drive shaft possible.

9、SAE 和 ISO 安装法兰。

SAE and ISO mounting flange.

一、型号说明 Ordering Code

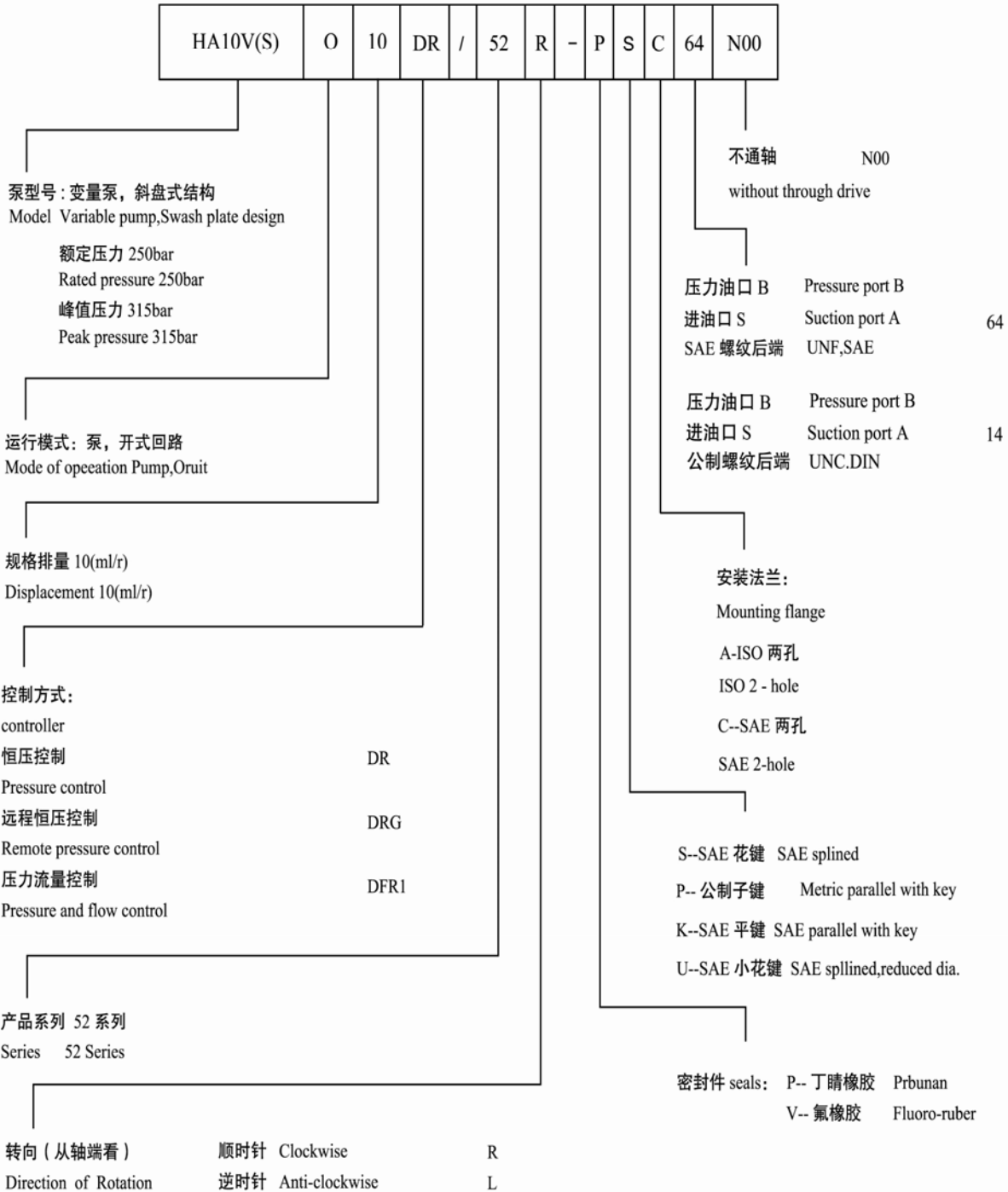

## 二、油液 Hydraulic Fluid

参见 31 系列 P24 Viewed on 31 Series P24

## 三、技术参数 Technical date

工作压力范围 Operation pressure range

在 B 口压力 Pressure at port B

额定压力 Rated pressure  $P_N$ .....250bar

峰值压力 Peak pressure  $P_{max}$ .....315bar

S 口 ( 进口 ) 的绝对压力 Inlet Operation Pressure at port S

$P_{abs\ min}$ .....0.8bar

$P_{abs\ max}$ .....30bar

### 参数关系 Parameter relations

$$\text{容积流量 flow } q_v = \frac{V_g \times n \times \eta_v}{1000} \quad [\text{L/min}]$$

$$\text{驱动转矩 drive torque } T = \frac{1.59 \times V_g \times \Delta p}{10 \times \eta_{mh}} = \frac{V_g \times \Delta p}{20 \times \pi \times \eta_{mh}} \quad [\text{N.m}]$$

$$\text{驱动功率 drive power } P = \frac{T \times n}{9549} = \frac{2\pi \times T \times n}{60000} = \frac{q_v \cdot \Delta p}{600 \cdot \eta_t} \quad [\text{kW}]$$

$V_g$  = 每转几何排量 [ $\text{cm}^3$ ]      Geometry displacement each rotate

$\Delta p$  = 压差 [bar]      Pressure drop/differential

$n$  = 转速 [rpm]      Rotary speed

$\eta_v$  = 容积效率      Cubage's efferency

$\eta_{mh}$  = 机械 - 液压效率      Mechaanical-Hydraulic efficiency

$\eta_t$  = 总效率 (  $\eta_t = \eta_v \cdot \eta_{mh}$  )      Overall efficiency

技术参数表 ( 理论值, 未考虑机械效率与容积效率 )

Technical data Form(theoretical values,without considering  $\eta_{mh}$  and  $\eta_v$  )

规格 Size				10
排量 Displacement		$V_{gmax}$	$\text{cm}^3$	10.5
在 $V_{g\ max}$ 时最高转速 <sup>1)</sup> Max speed when $V_{gmax}$		$N_{omax}$	rpm	3600
最高转速 maximum speed 当进口压力 $P_{abs}$ 增加或 $V_g < V_{gmax}$ 时 when pabs increase or $v_g < v_{gmax}$		$N_{max\ zu1}$	rpm	4300
最大流量 Max speed when $V_{gmax}$	at 在 $N_{omax}$ 时	$q_{vmax}$	L/min	37
	at 在 $n_{E=1450\text{min}^{-1}}$ 时		L/min	15
最大功率 Max power( $\Delta p=250\ \text{bar}$ )	at 在 $N_{omax}$ 时	$P_{omax}$	kW	16
	at 在 $n_{E=1450\text{min}^{-1}}$ 时		kW	6.5
最大转矩 Max torque( $\Delta p=250\ \text{bar}$ )	at 在 $V_{gmax}$ 时	$T_{max}$	Nm	42
惯性矩 Moment		J	$\text{kgm}^2$	0.0006
重量 Weight		m	kg	8
驱动轴上允许最大轴向力	the drive shaft allows maximun axial force	$F_{ax\ max}$	N	400
驱动轴上允许最大径向力	the drive shaft allows maximum radial force	$T_{ax\ max}$	N	250

## 四、安装注意事项 Installation Notes

参见 31 系列 P26 Viewed on 31 Series P26

五、安装连接尺寸 Mounting Dimension

HA10VSO 10 DR /52 R- XKC64N00型  
S  
L U

轴端 "K" Shaft end "K"

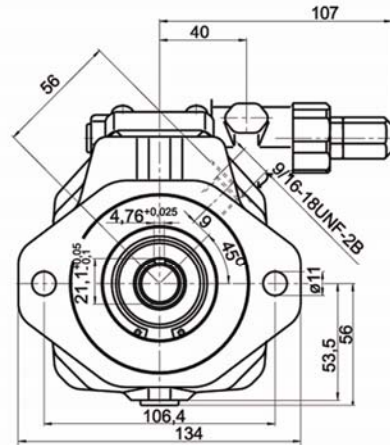
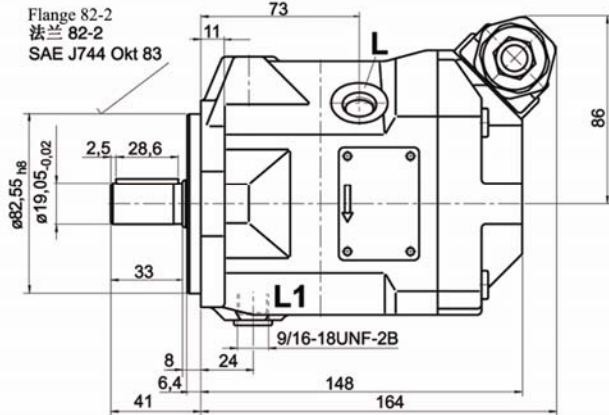

Y View  
Y向视图

图示为顺时针方向转动  
for clockwise rotation

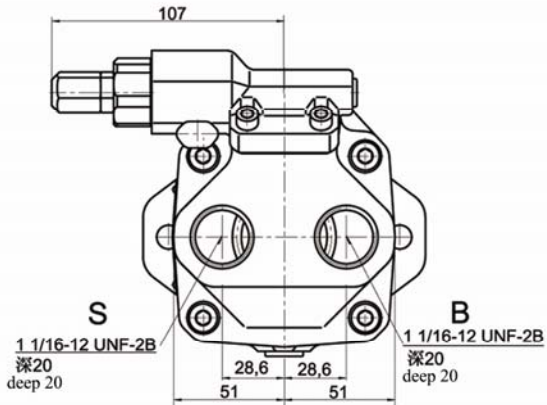

Y View  
Y向视图

图示为逆时针方向转动  
for counter clockwise rotation

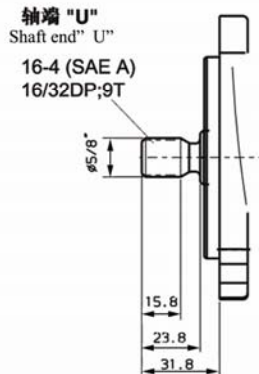
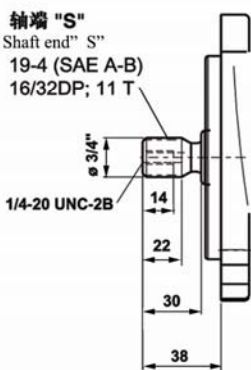
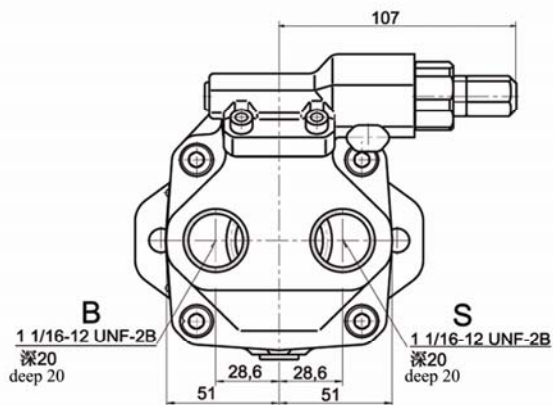

油口		Oil port	
B	压力油口	1 1/16-12UNF-2B	B Pressure oil port
S	进油口	1 1/16-12UNF-2B	S Inlet
L, L <sub>1</sub>	壳体泄油口	9/16-18UNF-2B	L, L <sub>1</sub> Case drain

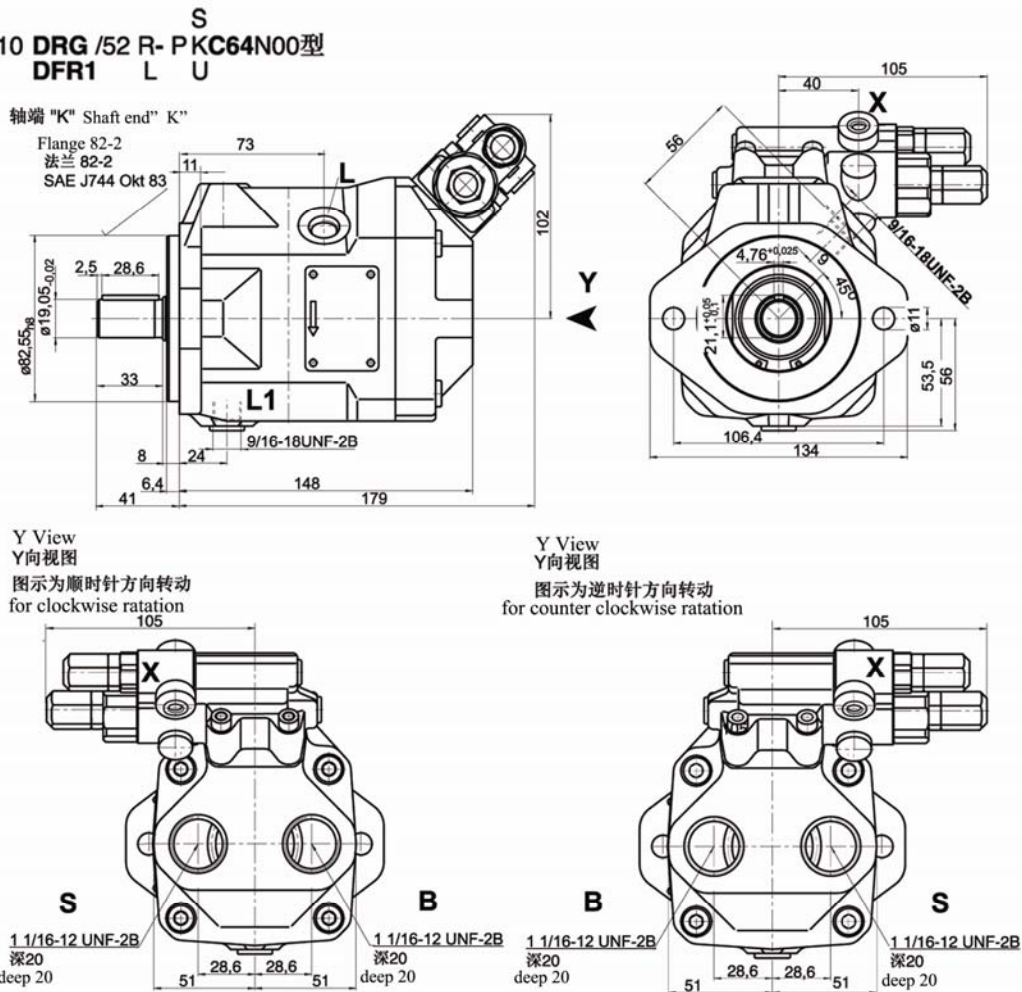
**HA10VSO 10 DRG /52 R- PKC64N00型**  
**DFR1 L U**

油口			Oil port
B	压力油口	1 1/16-12UNF-2B	B Pressure oil port
S	进油口	1 1/16-12UNF-2B	S Inlet
L, L <sub>1</sub>	壳体泄油口	9/16-18UNF-2B	L, L <sub>1</sub> Case drain
X	先导油口	7/16-20UNF-2B	X Control pressure oil port

HA10VSO 10 DR /52 R- XPA14N00型  
L

轴端 “P”  
shaft end “P”

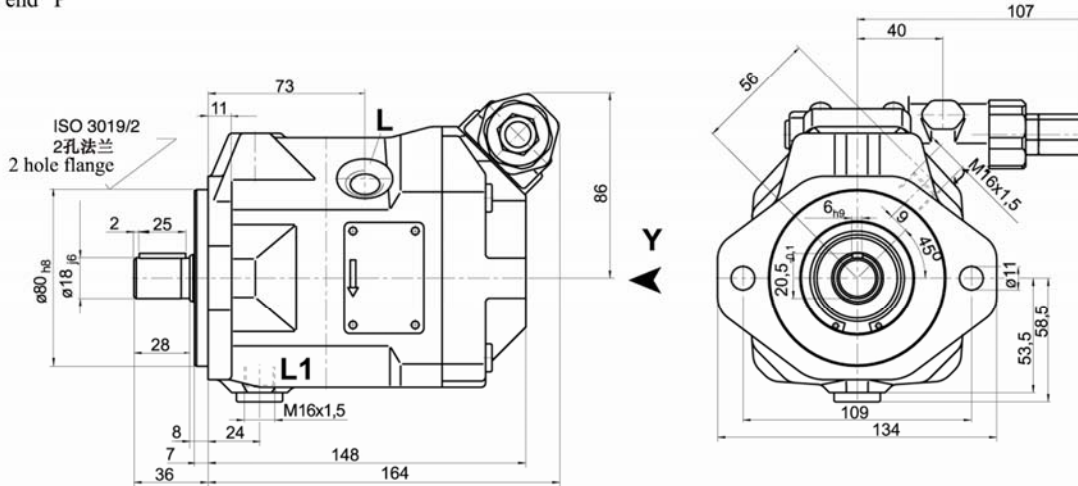

Y View  
Y向视图  
图示为顺时针方向转动  
for clockwise rotation

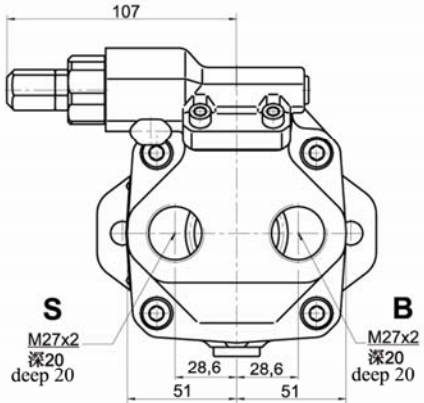

Y View  
Y向视图  
图示为逆时针方向转动  
for counter clockwise rotation

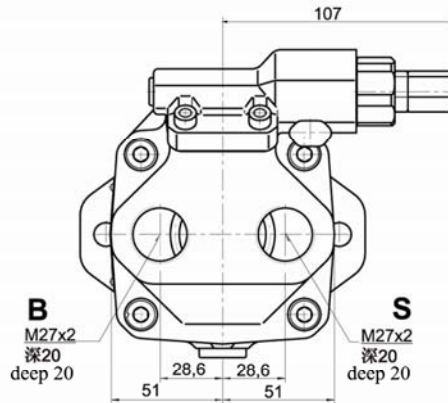

油口	Oil port		
B	压力油口	M27x2	B Pressure oil port
S	进油口	M27x2	S Inlet
L, L <sub>1</sub>	壳体泄油口	M16x1.5	L, L <sub>1</sub> Case drain



## 六、控制方式 Controller

### DR 压力控制 Pressure control

在压力控制范围内使液压系统中压力维持恒定，泵仅提供系统所需流量，压力可无级设定。

The pressure controller serves to maintain a constant pressure in a hydraulic system within the control range of the pump. The amount of hydraulic fluid required by the system. Pressure may be steplessly set at the control valve.

静态工作曲线 static characteristic  
(在  $n_1 = 1500 \text{ rpm}$  ;  $t_{oil} = 50^\circ\text{C}$ )  
(at  $n_1 = 1500 \text{ rpm}$ ;  $t_{oil} = 50^\circ\text{C}$ )

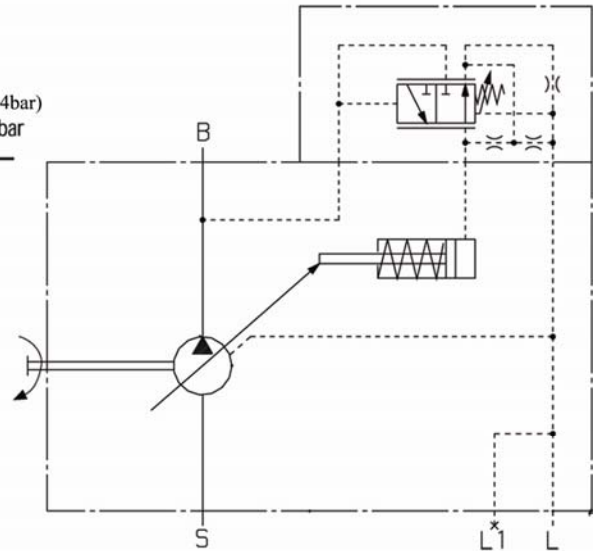
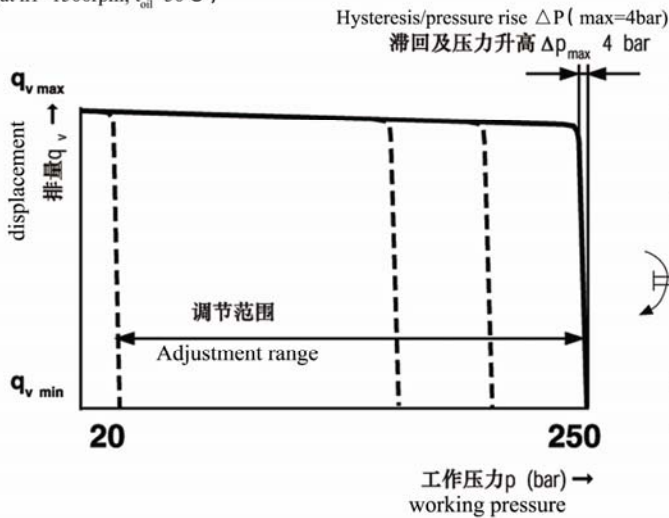

### DRG 远程恒压控制

#### Remote Pressure control

DRG 的功能和结构

Function and equipment same as DRG.

溢流阀可接在 X 口用作远程控制，溢流阀不在 DRG 供货范围内。

A pressure relief valves can be connected to port X for remote control applications, it is not included in the items supplied with the DRG control .

先导阀的标准压差为 20bar。需先导阀控制流量为 1.5L/Min。如需另外的设定值（范围在 10~22bar），请在订货文件中写明。

The differential pressure at the DRG-spool is set as standard to 20 bar, and this results in a pilot flow of approx.1,5 L/min.

If another setting is required(range between 145 and 320 psi (10 and 22 bar)), please state in clear text .

推荐采用下列分离安装溢流阀

As a separate pressure relief valve we can recommend below:

DBDH 6 (hydraulic)

管道最长不得超过 2m

The max. lenght of piping should not exceed 6.6 ft (2 m).



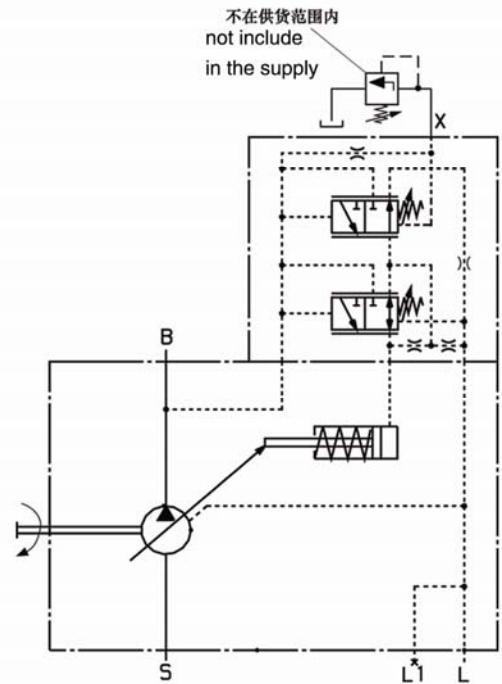
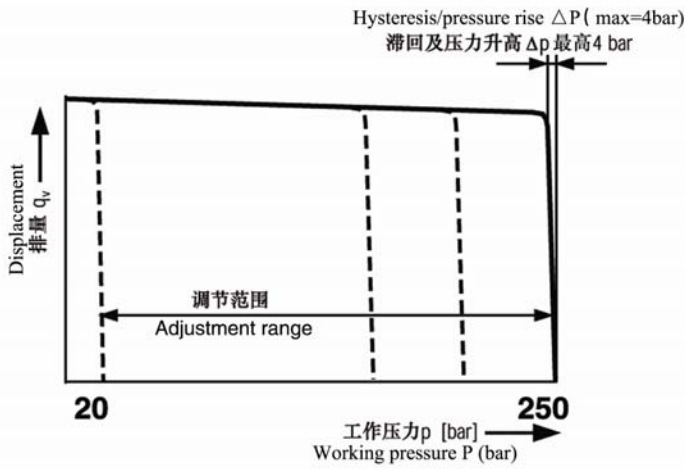

### DFR1 压力流量控制 Pressure and flow control

除了恒压功能外，借助于负载（如一节流孔）的压差可改变泵的流量。泵仅供执行机构所需流量。对 DFR1，X 口节流孔堵死。  
Function and equipment as for in addition to the pressure control function, the pump flow may be varied by means of a differential pressure over an orifice or valuespool, installed in the service line. The pump flow is equal to the actual required flow by the actuator  
The DFR1-value has no connection between X and the tank.

静态工作曲线 (在  $n_1 = 1500 \text{ rpm}$  ;  $t_{oil} = 50^\circ\text{C}$ )

Static characteristic (at  $n_1=1500\text{rpm}$ ;  $t_{oil}=50^\circ\text{C}$ )

